

Ultra Hygienic Applications

W+ SERIES



Engineering excellence, allied to stringent quality control, ensures that APV's unrivalled range of products complies with the highest international standards for hygiene. In the light of growing pressure worldwide to deliver safe, high quality food, all APV products are designed for easy cleanability, while minimizing the use of valuable resources, such as energy.

The APV product portfolio includes a wide range of pumps, valves, heat exchangers, mixers and homogenizers designed for use in the food, dairy and brewing industries, as well as in chemical, healthcare, pharmaceutical processing and heavy industries.

The pharmaceutical industry is characterised by increasing demands in verification, validation and certification.

Pharmaceutical processes are subject to different laws and higher safety standards than those for other applications. Consequently, the selection of materials, CIP and SIP capabilities as well as design features of pumps play a major role in assuring the quality of a pharmaceutical plant.

To meet these challenges head on, you need a partner with a deep understanding of process engineering and a broad portfolio of equipment. Look to SPX FLOW and our industry leading brands to provide unparalleled technical support, equipment versatility and expertise.

Explore the endless solutions that SPX FLOW has to offer. You're sure to find answers that will improve plant performance, increase profitability and enhance the value of your brand.

W+ Series - Advanced Design for Performance and Reliability

The W+ is the most modern sanitary centrifugal pump in the market today, with a strong focus on hygiene. This includes the strict demands within the pharmaceutical industry, i.e. W+ pumps are available in special designs where product contact parts (impeller, impeller nut and back plate) are machined from solid 316L SS and with electro polished surface. The deep-drawn casing is polished to Ra < 0,5 µm contact surface finish and electro polished. Other optional features are casing drain, multiple outlet positions and certifications of materials and surface finish.

PRODUCT FEATURES AND BENEFITS:

- Reliable and heavy duty design
- Energy efficient
- Quiet performance with minimal vibration
- Superior shaft seal design
- High pressure capability
- 3-A (optional)
- Unique zero dead leg casing drain
- Designed for CIP (Cleaning In Place) as well as SIP (Sterilizing In Place)
- Suitable for wide variety of products
- Wide range of optional features available
- Easy and cost effective maintenance



DESIGNED FOR EFFICIENCY

The W+ pump series is based on a unique hydraulic design that ensures maximum efficiency, allows for highest hygienic standards and reduces noise and vibration.

- **Item 1** - Unique APV spiral volute positioned in the backplate of the pump ensures a direct transfer of liquid from inlet to outlet
- **Item 2** - Advanced, high efficiency impeller design
- **Item 3** - Extended outlets smooth transition to process piping while reducing turbulence and preventing product build-up
- **Item 4** - Heavy walled pump casing ensures that efficiency levels are maintained even at high pressure

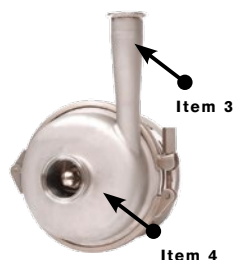

SEALING AREA DESIGNED FOR HYGIENIC APPLICATIONS:

The shaft seal area is essential in terms of hygiene. W+ pumps are designed without dead pockets and for frequent exchange of liquid. The pumps are equipped with a shaft seal that is ideal for hygienic applications.

SEAL ADVANTAGES:

- Internal seal design optimizes cooling and lubrication of seal surfaces while the seal chamber is built to efficiently dissipate heat. Both work to reduce risk of "dry-running"
- Directed flow assures thorough cleaning of seal area
- The stationary spring is located outside the product contact area to maintain cleanliness
- Two sizes cover all models (excl. W+50/600)
- Front loading seal simplifies maintenance: only the pump housing and impeller have to be disassembled, then the shaft seal can be replaced quickly from the front
- Can easily be rebuilt into a double mechanical shaft seal for use with water flushing or with a barrier medium for aseptic applications
- Double mechanical is mirror image of single: same seal faces and o-rings

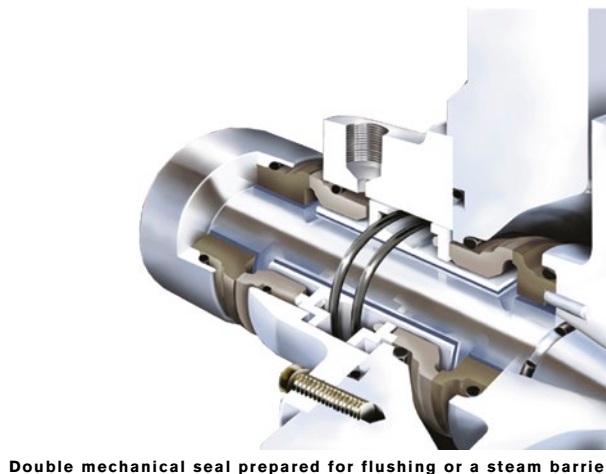
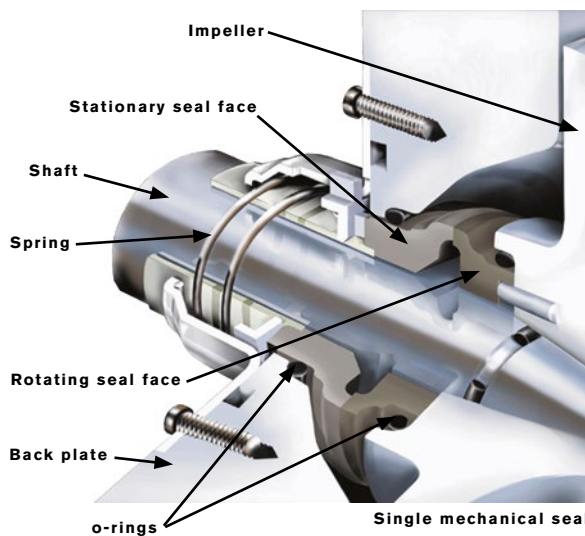

Typical Product Applications

W+ is a pump designed to meet the highest demands required by e.g. pure water applications in the pharmaceutical and biotech industries

Pharmaceutical and Biotech

Water, Deionized
Water, Demineralized
Water, Distilled
WFI (Water for Injection)
Emulsions
Extracts
Vaccines
Antibiotics
Sugar solutions
Alcohols
Solvents
Ultra filtration processes



and other processes with the highest hygienic demands

KEY FEATURES:

W+ pumps are available in a number of special versions, which may be adapted specifically to customer requirements. Furthermore, pumps are available with 3-A and a variety of other certificates or validation documents for the most demanding needs.

The W+ pump is available with a unique “zero dead leg” drain solution.

The integration of the aseptic DELTA AP1 diaphragm valve and the W+ pump enables this unique solution. Standard option for W+50/8, W+55/35, W+55/60, W+70/40. For other models, please ask SPX FLOW.



The DELTA AP1 valve is available in a hand operated and a pneumatic version.



WI+

The inducer pump is the alternative to changing the process design when NPSH availability is low.

The inducer boosts the inlet pressure, and the risk of cavitation is correspondingly reduced (the NPSH required typically drops by 50-70%). When the risk of cavitation disappears, so does the risk of a large number of operational disturbances that would otherwise result - such as excessive noise, energy loss, product damage and unnecessary wear on the pump.

The Wi+ is unique among inducer pumps, since the NPSH requirement is kept to a minimum throughout a large operating range.

Other Options:

- WFI (Water For Injection) shaft seal design
- Double mechanical shaft seal
- Casing with socket for drain connection
- Multiple outlet positions, e.g. to avoid air entrapment
- Product wetted surface mechanical polish to $Ra < 0,8 \mu\text{m}$ (3-A)
- Electropolished product wetted surface ($Ra < 0,5 \mu\text{m}$)

Examples of Certificates Optionally Available:

- Flow and pressure tests
- Cleanability certificates as 3-A
- Material certificates as 3.1, FDA and USP Class VI
- Certificates of surface roughness, welding and electro polishing
- ATEX certificates (Hazardous zone)
- Quality certification (ISO 9001)

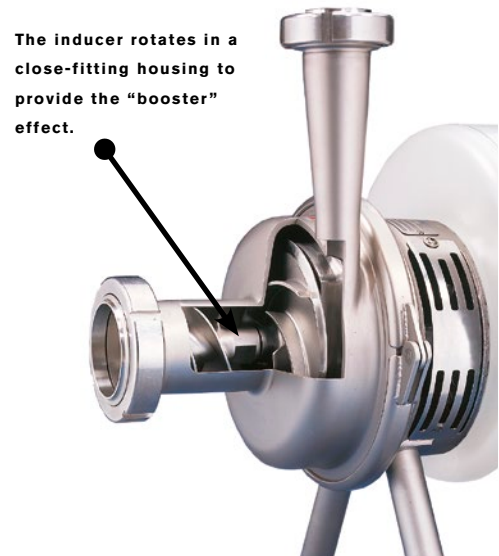

PUMP SPECIFICATIONS:

MATERIALS		
CASING	SS 316L	Special optional product contact finish: Ra < 0.8 µm (3-A) Ra < 0.5 µm and electro polished* Castings are not used for electro polished parts.
IMPELLER	SS 316L	
IMPELLER NUT	SS 316L	
INDUCER (WI+)	SS 316L	
BACK PLATE	SS 316L	
SHAFT	SS 316L	Parts are not product wetted
CLAMP RING	SS 304	
EXTENSION FRAME	SS 304	
LEGS	SS 304	
MOTOR SHROUD	SS 304	
SHAFT SEAL	Carbon/Silicon Carbide Optional: Silicon Carbide/Silicon Carbide	Special optional WFI seal: Silicon Carbide/Silicon Carbide with Graphite
ELASTOMERS	EPDM, (FDA Compliant) Optional: FPM, (FDA Compliant) FEP encapsulated FPM, (FDA Compliant)	Special optional certification: EPDM USP Class VI, 70°C (158°F) or 121°C (250°F)
TECHNICAL DATA		
MAX. DISCHARGE PRESSURE	18 bar (116 psi): W+10/8, W+22/20, W+30/80, W+35/55, W+35/35, W+110/130 14 bar (203 psi): W+25/210, W+30/120, W+50/8, W+55/35, W+55/60, W+60/110, W+65/350, W+70/40, W+80/80 Optional: Heavy duty clamping ring, increasing max. outlet pressure to 25 bar (362 psi): W+30/120, W+55/35, W+55/60, W+60/110, W+70/40 20 bar: W+80/80	
MAX. OPERATING TEMPERATURE	95°C (203°F) as standard. >95°C (203°F), please contact SPX FLOW	
CONNECTIONS		
W+ pumps can be supplied with all standard threads and clamps in accordance to DS, BS, DIN, SMS and ISO as well as DIN flanges.		
MOTOR		
IEC metric standard, 2, 4 or 6 poles, at 50/60 Hz, IP55, insulation class F. W+ pumps are as standard in Europe delivered with motors meeting the IE2 efficiency level in accordance to the Directive 2005/32/EC Eco-design of Energy using Products.		

*Standard option for the following models: W+10/8, W+22/20, W+30/80, W+35/35, W+35/55, W+50/8, W+55/35, W+55/60, W+60/110, W+70/40, W+80/80. For other models or special surface finish requirements, please ask SPX FLOW.

W+ pumps meet the requirements of the Regulation (EC) No 1935/2004 on materials and articles intended to come into contact with food and repealing Directives 80/590/EEC and 89/109/EEC.

RANGE:

The W+ range consists of 17 standard models with pressure and flow capacities up to 15 bar (217 psi) (50 Hz) and up to 725 m³/h (3,192 g/h) (50 Hz).

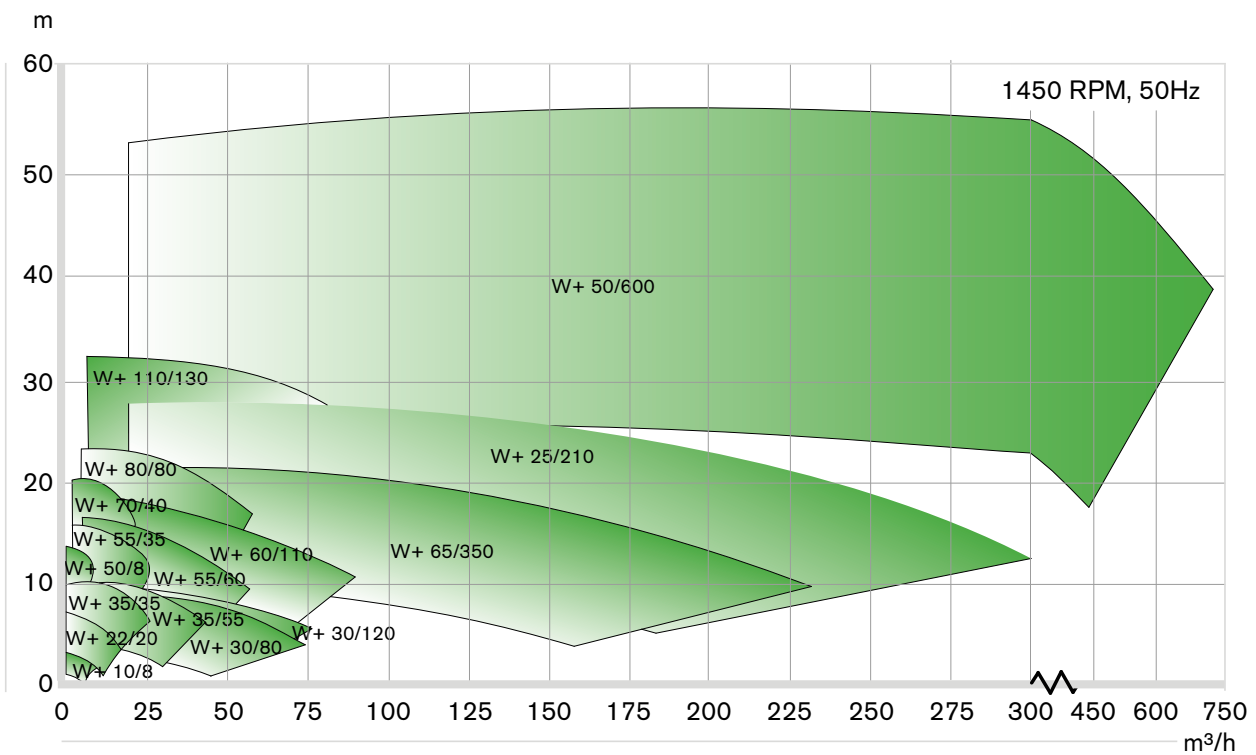
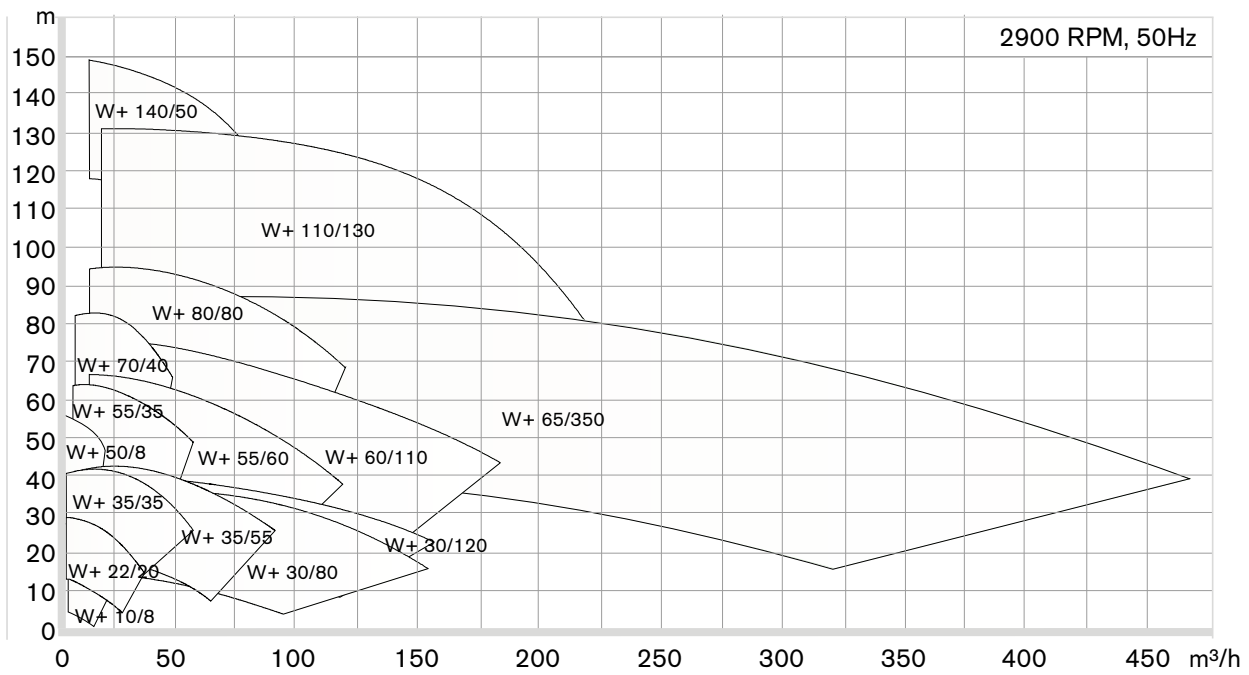

W+35/35



W+80/80



W+50/600

W+ VARIATIONS:

Ws+ Self-Priming Pump

The self-priming Ws+ is designed to handle CIP return and other fluids with entrained air and foam. The unique design reduces the energy consumption and noise of traditional liquid ring pumps by using a high efficiency impeller that can be trimmed to match a specific duty.

The Ws+ employs a built in eccentric air screw to form the liquid ring required for its self-priming capability.

- Ideal for CIP return
- Extremely clean design
- Superior shaft seal design
- Higher efficiency
- Noise reduction
- Parts interchangeability with W+ centrifugal series
- Particle friendly design
- 3-A (optional)
- Designed for CIP (Cleaning In Place) as well as SIP (Sterilizing In Place)
- Available with electropolished product wetted surface ($R_a < 0.5 \mu\text{m}$)



Whp+ High Pressure Pump

The Whp+ is a high-pressure model of the W+ range. The pumps are designed to withstand system pressures up to 60 bar (870 psi). The Whp+ pump's sturdy construction increases stability and dampens vibrations.

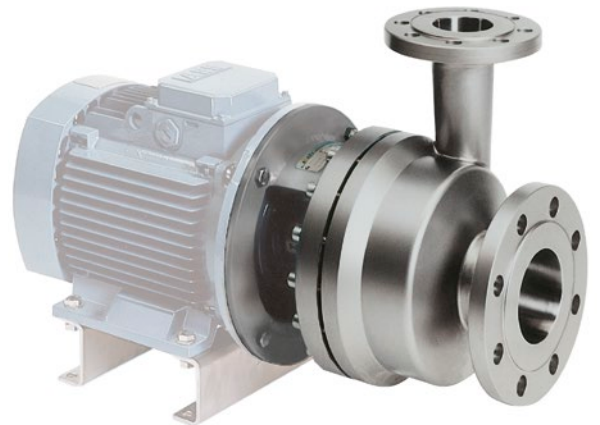

Wa+ Aseptic Pump

All seals, including the shaft seal, are designed as double seals.

- Double mechanical shaft seals fitted for sterile flushing
- Double o-ring sealing of pump housing fitted for sterile flushing
- Special aseptic fittings fitted for sterile flushing

Wa+ pumps ensure absolutely aseptic production processes with barrier media up to 150°C (302°F). With a Wa+ pump, the risk of contaminating the product and environment is thus reduced to an absolute minimum.

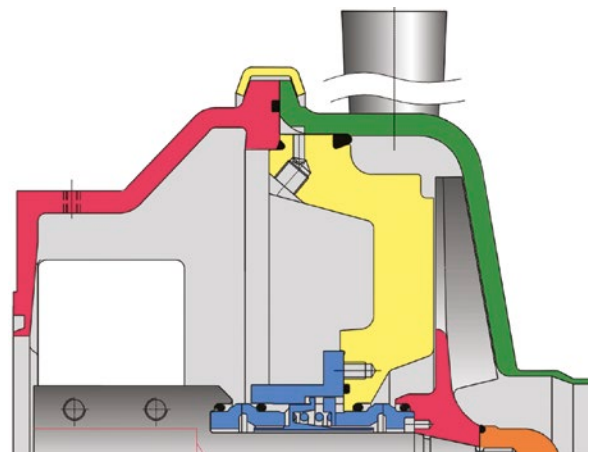

APV Ultra Hygienic Applications

W+SERIES



SPX FLOW, Inc. (NYSE:FLOW) is a leading manufacturer of innovative flow technologies, many of which help define the industry standard in the market segments they serve. From its headquarters in Charlotte, North Carolina, it operates a sales and support network, centers of manufacturing excellence, and advanced engineering facilities, throughout the world. Its cutting-edge flow components and process equipment portfolio includes a wide range of pumps, valves, heat exchangers, mixers, homogenizers, separators, filters, UHT, and drying technology that meet many application needs. Its expert engineering capability also makes it a premium supplier of customized solutions and complete, turn-key packages to meet the most exacting of installation demands.

Incorporating many leading brands, SPX FLOW has a long history of serving the food and beverage, power and energy, and industrial market sectors. Its designs and engineered solutions help customers drive efficiency and productivity, increase quality and reliability, and meet the latest regulatory demands. In-depth understanding of applications and processes, state-of-the-art Innovation Centers, and advanced pilot/testing technology further assist in optimizing processes and reducing timescales to reliably meet production targets.

To learn more about SPX FLOW capabilities, its latest technology innovations and complete service offerings, please visit www.spxflow.com.

QUESTIONS OR INQUIRIES

FIND YOUR LOCAL CONTACT ON OUR WEBSITE: www.spxflow.com/apv/support/

SPX FLOW, Inc. reserves the right to incorporate our latest design and material changes without notice or obligation.

Design features, materials of construction and dimensional data, as described in this bulletin, are provided for your information only and should not be relied upon unless confirmed in writing. Please contact your local sales representative for product availability in your region. For more information visit www.spxflow.com.

The green "s" and "x" are trademarks of SPX FLOW, Inc.